

## Specification Status: Released

Not to be used for new designs. For new design please contact Tyco Electronics Sales

### BENEFITS

- Board space savings
- Help protect sensitive electronic circuits against damage from electrostatic discharge (ESD)
- Assist equipment to pass IEC 61000-4-2, level 4 testing

### FEATURES

- Thick film technology
- Low capacitance (0.25 pF typical)
- Low trigger voltage
- Low clamping voltage
- Capable of withstanding numerous ESD strikes
- Compatible with standard reflow installation procedures
- Bi-directional protection

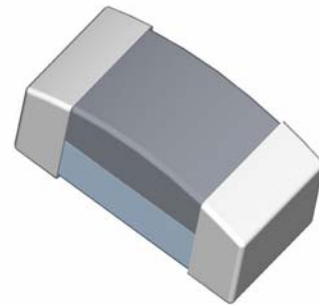

### APPLICATIONS

- Cellular phones

**Caution:** This part is not intended to be used under bias, nor for power bus nor data line applications. It is only to be used in RF applications.

### MATERIALS INFORMATION

ROHS Compliant

Directive 2002/95/EC  
Compliant

ELV Compliant

Directive 2000/53/EC  
Compliant

### PART NUMBERING

Series PESD 0402 - 060 Operating Voltage Designator  
 $6 \times 10^0 = 6V_{DC}$

EIA Size \_\_\_\_\_

The operating voltage is used to measure leakage current @ 1s



**TYPICAL TRANSMISSION LINE PULSE RESPONSE GRAPH**

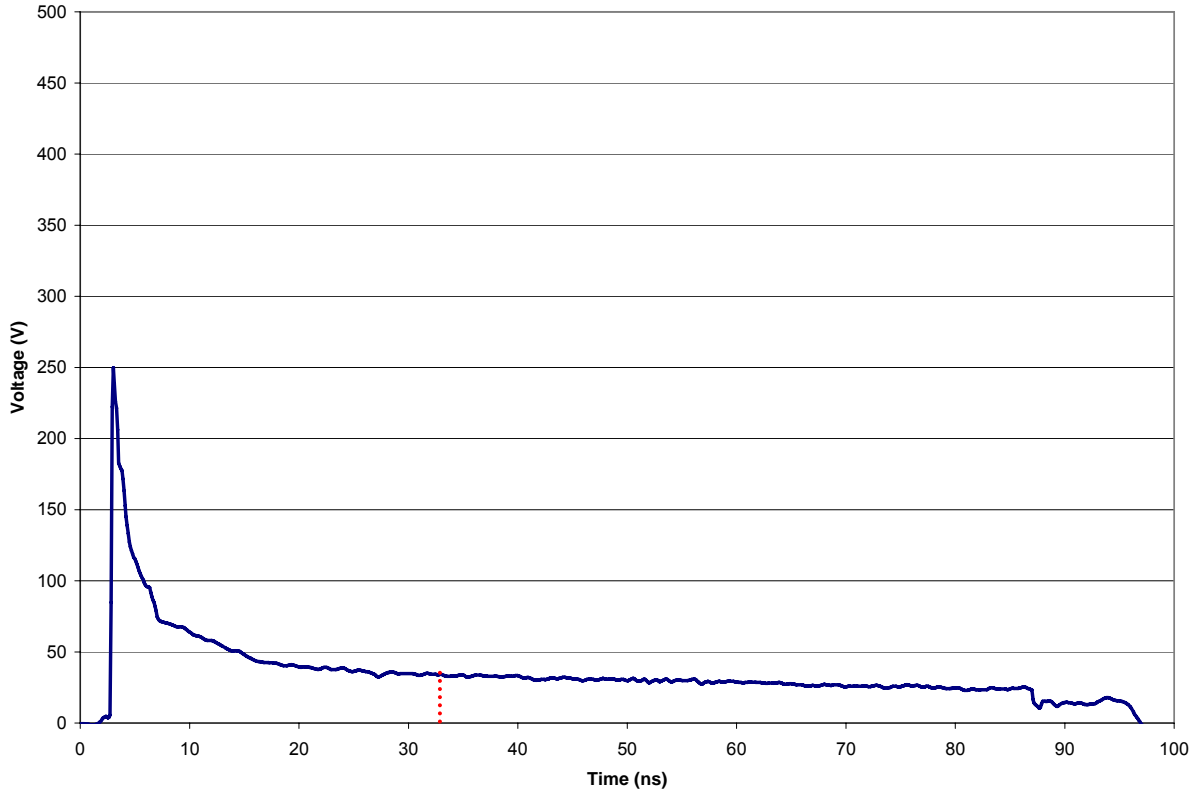

**ESD Protector**  
Overvoltage Protection Device

*Raychem Circuit Protection Products*

**PRODUCT: PESD0402-060**

DOCUMENT: SCD 26105  
REV LETTER: I  
REV DATE: DECEMBER 7, 2007  
PAGE NO.: 4 OF 8

**DIMENSIONS**

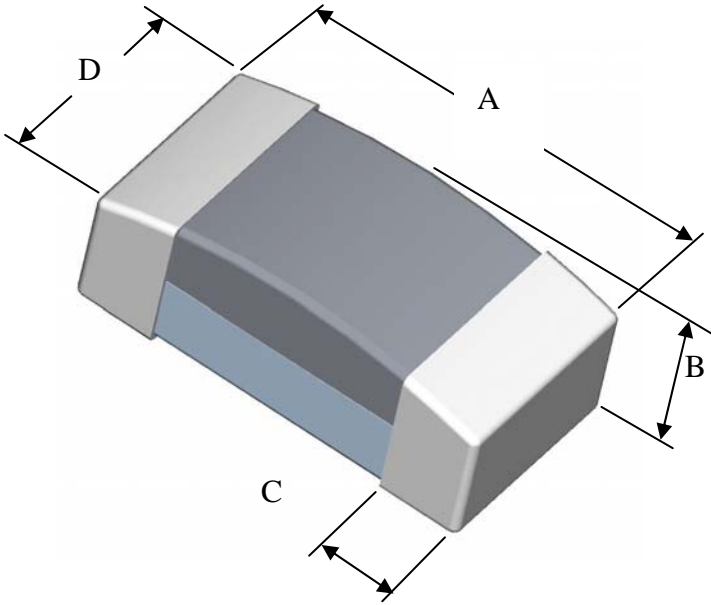

Drawing Not To Scale

	Length A		Height B		Terminal Width C		Width D	
	MIN	MAX	MIN	MAX	MIN	MAX	MIN	MAX
mm:	0.95	1.05	0.28	0.43	0.1	0.3	0.45	0.55
in*:	(0.037)	(0.041)	(0.008)	(0.017)	(0.004)	(0.010)	(0.018)	(0.022)

\*Rounded off approximation

**ESD Protector**  
**Overvoltage Protection Device**

*Raychem Circuit Protection Products*

**PRODUCT: PESD0402-060**

DOCUMENT: SCD 26105  
 REV LETTER: I  
 REV DATE: DECEMBER 7, 2007  
 PAGE NO.: 5 OF 8

**RECOMMENDED LAND PATTERN:**

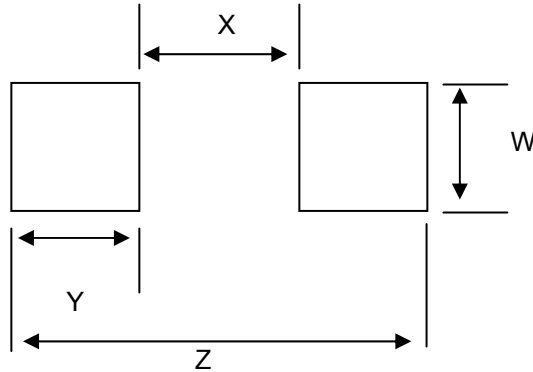

Solder thickness 0.15 to 0.2mm

	W		X		Y (Ref)		Z	
	Min	Max	Min	Max	Min	Max	Min	Max
mm:	0.6	0.7	0.3	0.4	0.8	0.9	2.1	2.2
in: *	(0.024)	(0.028)	(0.012)	(0.016)	(0.031)	(0.035)	0.083)	(0.087)

\*Rounded off approximation.

**SOLDER REFLOW RECOMMENDATIONS:**

A	Temperature ramp up 1	From ambient to Preheating temperature	30s to 60s
B	Preheating	140°C - 160°C	60s to 120s
C	Temperature ramp up 2	From Preheating to Main heating temperature	20s to 40s
D	Main heating	at 200°C at 220°C at 240°C at 260°C	60s ~ 70s 50s ~ 60s 30s ~ 40s 5s ~ 10s
E	Cooling	From main heating temperature to 100°C	max 4°C/s

**ESD Protector**  
 Overvoltage Protection Device

*Raychem Circuit Protection Products*

**PRODUCT: PESD0402-060**

DOCUMENT: SCD 26105  
 REV LETTER: I  
 REV DATE: DECEMBER 7, 2007  
 PAGE NO.: 6 OF 8

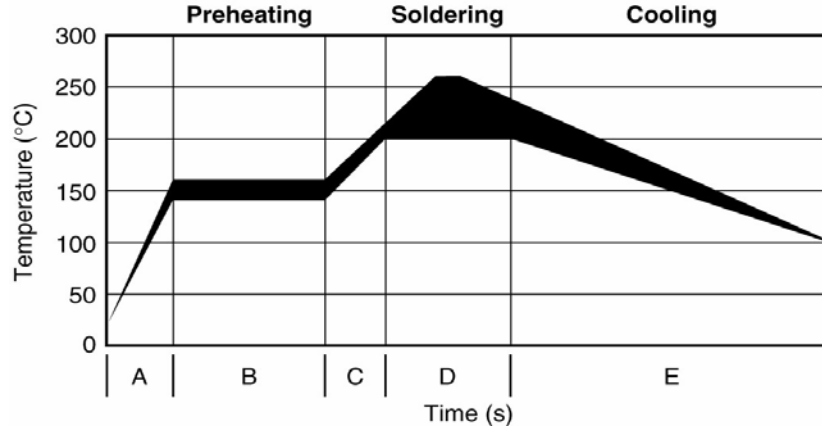

**PACKAGING**

Packaging	Tape & Reel	Standard Box
PESD0402-060	10,000	50,000

**EIA referenced Reel Dimensions for PESD Devices**

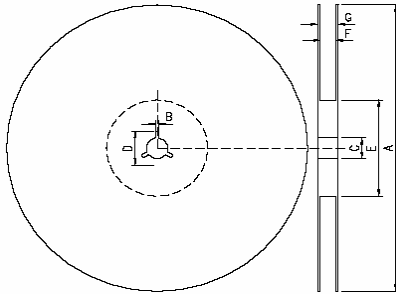

**Reel Dimensions (mm):**

	A	B	C	D	E	F	G
<b>0402 Devices</b>	178.0 ±2.0	2.0 ±0.5	13.0±0.5	21.0±0.8	62.0±1.5	9.0±0.5	13.0±1.0

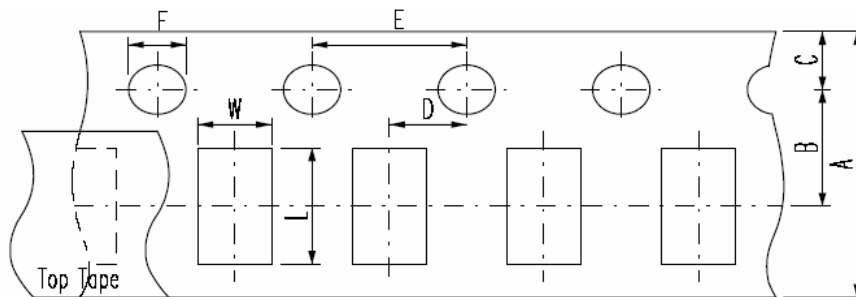

**Carrier Dimensions (mm):**

	A	B	C	D	E	F	L	W	T
<b>0402 Devices</b>	8.0±0.3	3.5±0.05	1.75±0.1	2.0±0.05	4.0±0.1	1.5±0.1	1.15±0.2	0.65±0.05	0.40±0.05

**Product Orientation** – always face up (meaning the substrate is at the bottom), but parts do not have polarity mark.

**Leader & Trailer:** The leader is 180mm in length & consists of empty cavities with sealed cover tape.

The trailer is 350mm in length & consists of empty cavities with sealed cover tape.

## **POST REFLOW, CLEANING CONDITIONS**

A 5% saponifier combined with water during wash.

For Ultrasonic process water temperature should be at 50°C and board should be submerged for a minimum of one minute in the solutions, then rinse and dry.

For in-line washing, the temperature of the water sprayed should be at 110°C, rinse and drying is done in-line.



**Warning: Application Limitations for PESD0402-060. This part is not intended to be used under bias, nor for power bus nor data line applications. It is only to be used in RF applications. Users should independently evaluate the suitability of and test each product selected for their own applications**

Information furnished is believed to be accurate and reliable. However, users should independently evaluate the suitability of and test each product selected for their own applications. Tyco Electronics reserves the right to change or update, without notice, any information contained in this publication; to change, without notice, the design, construction, processing, or specification of any product; and to discontinue or limit production or distribution of any product. This publication supersedes and replaces all information previously supplied. Without expressed or written consent by an officer of Tyco Electronics, Tyco Electronics does not authorize the use of any of its products as components in nuclear facility applications, aerospace, or in critical life support devices or systems. Tyco Electronics expressly disclaims all implied warranties regarding the information contained herein, including, but not limited to, any implied warranties of merchantability or fitness for a particular purpose. Tyco Electronics' only obligations are those in the Tyco Electronics Standard Terms and Conditions of Sale and in no case will Tyco Electronics be liable for any incidental, indirect, or consequential damages arising from the sale, resale, use, or misuse of its products.